

3A, Low Dropout, Fast Transient Linear Regulator

General Description

The ASD3930X are family of very low dropout voltage linear regulators with excellent line and load regulation. They are capable of delivering 3A of output current with typical dropout voltage of 380mV. The devices are designed to operate with wide input voltage range of 2.5 – 16 Volts and are available in either fixed or adjustable output Voltages.

The regulators includes an enable pin for electrical on/off of the regulator. Forcing the enable pin to logic low shuts down the LDO and reduces the supply current. An open drain power good allows easy sequencing with external regulators.

The ASD3930X family offer complete short-circuit and thermal protection. The combination of these two internal protection circuits gives the device a comprehensive safety system to safe guard against extreme adverse operating conditions. In addition, when the input voltage is removed, the reverse battery protection prohibits the output voltage shorting to the input voltage.

The ASD3930X families are available in thermally enhanced TO263-3 and 5 pin packages. The devices are rated for -40°C to +125°C temperature range.

Features

- V_{IN} range: 2.5 – 26V
- Adjustable and fixed V_{OUT} to as low as 1.24V
- 3A maximum output current
- 380mV of typical dropout voltage at full load
- Low shutdown current
- Excellent load and Line regulation at full load
- Enable pin for LDO on/off
- Power good output
- Fast transient response
- Reverse battery protection
- Current Limit protection
- Over-Temperature Shutdown
- -40 to +85°C temperature range
- Available in TO263 and TO252 packages
- RoHS & WEEE compliant

Applications

- Telecommunication and networking
- Medical equipment
- Servers
- Printers
- Post regulators for switching power supply

Typical Application

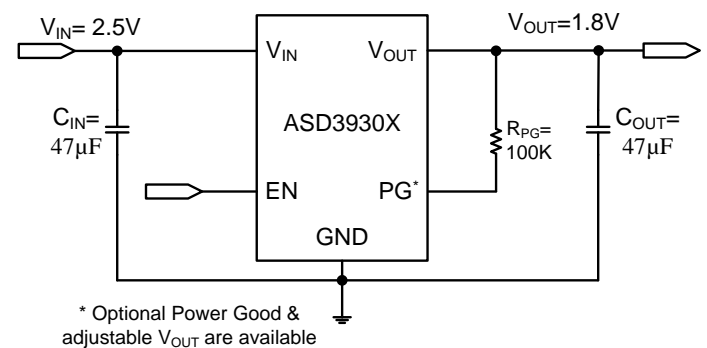

Pin Description (ASD39300)

Pin #	Symbol	Description
1	V_{IN}	Input supply pin. Connect a 47 μ F capacitor between this pin and ground.
2, Tab	GND	Ground connection.
3	V_{OUT}	Regulated output Voltage. Connect a 47 μ F capacitor from this pin to ground.

Pin Configuration (ASD39300)

TO263-3 & TO220-3 (Top View)

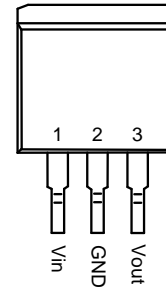

Pin Description (ASD39301/39302)

Symbol	Description
EN	Enable pin. It controls the electrical on/off of the device. When connected to logic low, the device shuts off. Logic high will resume normal operation
V_{IN}	Input supply pin. Connect a 47 μ F capacitor between this pin and ground.
GND	Ground connection.
V_{OUT}	Regulated output Voltage. Connect a 47 μ F capacitor from this pin to ground. See application section for the type of capacitor
Adj	Feedback Voltage. A resistor network of two resistors is used to set-up the output voltage connected between V_{out} and GND. The center tap of the two resistors is connected to Feedback pin.
PG	Power Good pin. It is an open collector, active high output that indicates the status of the output voltage. When output voltage (V_{OUT}) exceeds the PG trip threshold, the PG pin goes in to a high impedance state. When the device is out of regulation or shutdown, the PG pin is pulled low. A 10K Ω to 1M Ω resistor should be connected from PG to V_{OUT} .

Pin Configuration (ASD39301)

TO263-5 & TO220-5 (Top View)

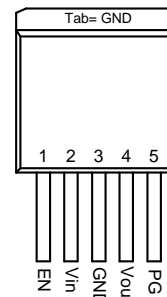

Pin Configuration (ASD39302)

TO263-5 & TO220-5 (Top View)

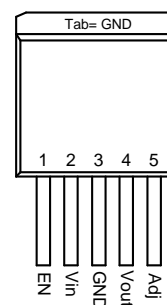

Absolute Maximum Ratings ⁽¹⁾

Maximum Input Supply Voltage	-0.3V to 20V
Enable Voltage20V

Recommended Operating Conditions

Input Voltage	2.5 to 16V
Enable Voltage16V
Ambient Operating Temperature	-40°C to +85°C

Thermal Information ⁽²⁾

TO263 θ_{JA}2°C/W
TO220 θ_{JA}2°C/W
Storage Temperature Range	-65 to 150°C
Lead Temperature (soldering 10s)260°C
Junction Temperature	-40°C to +125°C

Electrical Characteristics

UNLESS OTHERWISE NOTED: $V_{IN}=5V$; $V_{OUT}=3.3V$; $C_{IN}=C_{OUT}=47\mu F$; $-40^{\circ}C \leq T_A = T_J \leq 85^{\circ}C$; $T_{J(MAX)} = 125^{\circ}C$; TYPICAL VALUES ARE $T_A = 25^{\circ}C$

Parameter	Symbol	Conditions	Min.	Typ.	Max.	Units
Output Voltage Range	V_O	Adjustable only	1.24		15.5	V
Feedback Voltage Accuracy	V_{FB}		1.215	1.24	1.265	V
Maximum Output Current	I_O		3.0			A
Supply Current	I_Q	$I_{OUT}=750mA$		9	20	mA
Shutdown Current	I_{SHDN}	$V_{EN}=GND$; $V_{IN}=16V$		120	500	μA
Current Limit	I_{LIM}			4.5		A
Load Regulation ³		$I_{OUT}= 10mA - 3.0A$		0.1	1.0	%
Line Regulation		$V_{IN}=4.0 - 26V$; $I_{OUT}=10mA$		0.12	0.5	%
Dropout Voltage	V_{DO}	$I_{OUT}=500mA$		125		mV
		$I_{OUT}=1.0A$		258		
		$I_{OUT}=3A$		400		
Enable Threshold Low	$V_{EN(L)}$				0.8	V
Enable Threshold High	$V_{EN(H)}$		2.5			V
Input Enable Low Current	$I_{EN(L)}$	$V_{EN} = 0.8V$		2.0	4.0	μA
Input Enable High Current	$I_{EN(H)}$	$V_{EN}=2.5$		23	75	μA
Power good low threshold	V_{PG}	% of V_{OUT}	93			%
Power good high threshold	V_{PG}	% of V_{OUT}			99.2	%
Power good low voltage	$V_{PG(L)}$	$I_{PG_SINK}=250 \mu A$; $V_{IN}=2.5V$		220	400	mA
Thermal Shutdown	T_{SD}			150		°C
Thermal Shutdown Hysteresis	T_{SD_HYS}			10		°C

Notes:

1. Stresses above those listed in Absolute Maximum Ratings may cause permanent damage to the device.
2. Measured on approximately 1" square of 1oz copper
3. The ASD3930X is guaranteed to meet performance specifications over the -40°C to +125°C operating temperature range and is assured by design, characterization, and correlation with statistical process control.
4. Low duty cycle pulse testing with Kelvin connection required.

Functional Block Diagram

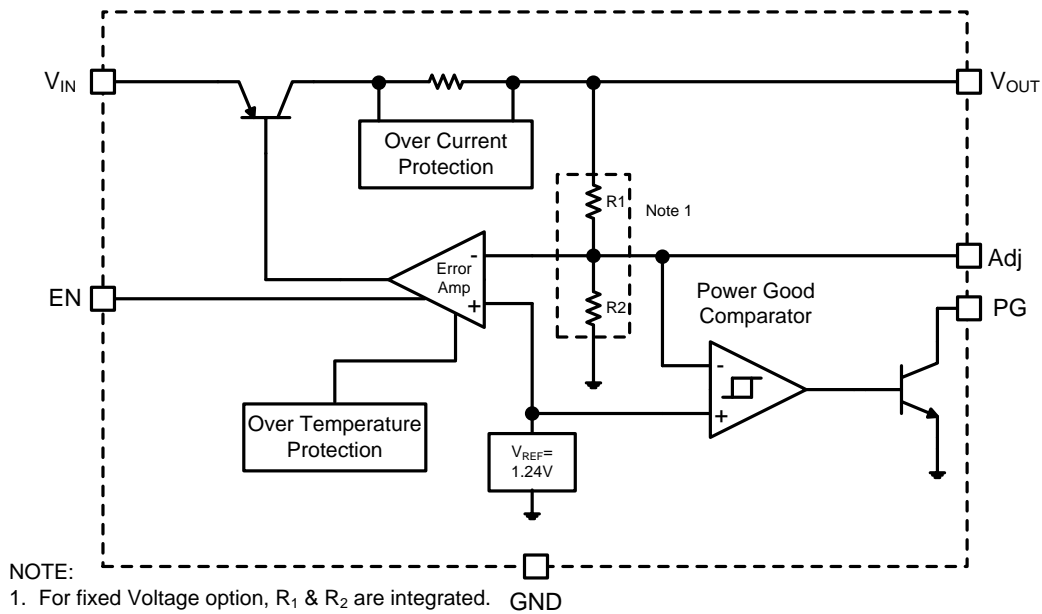

Typical Characteristics

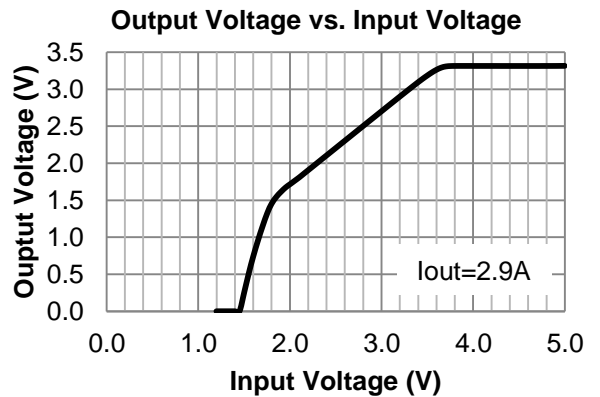
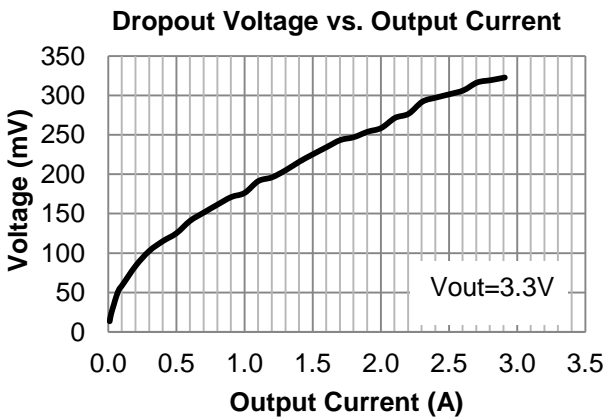
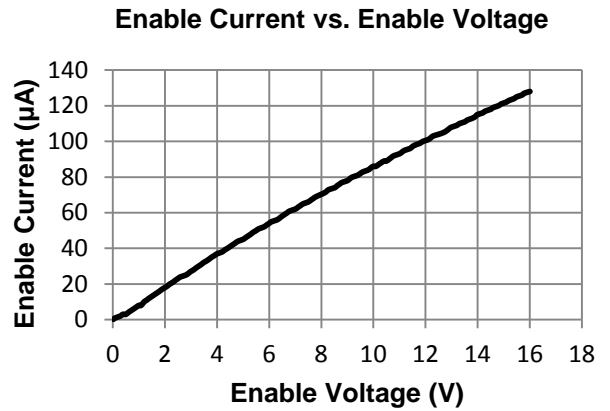
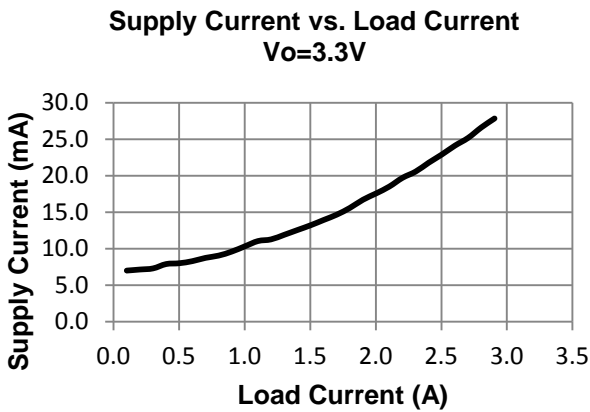
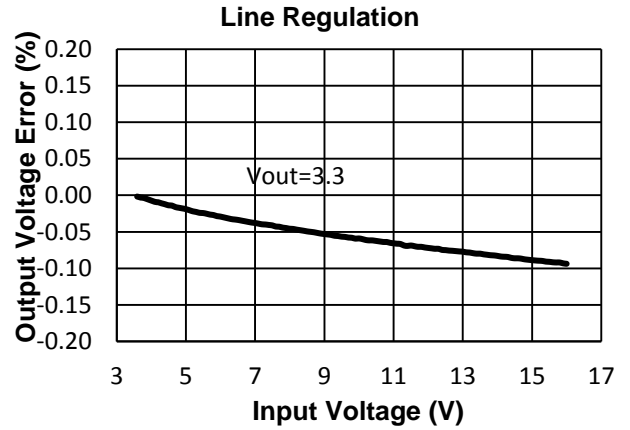
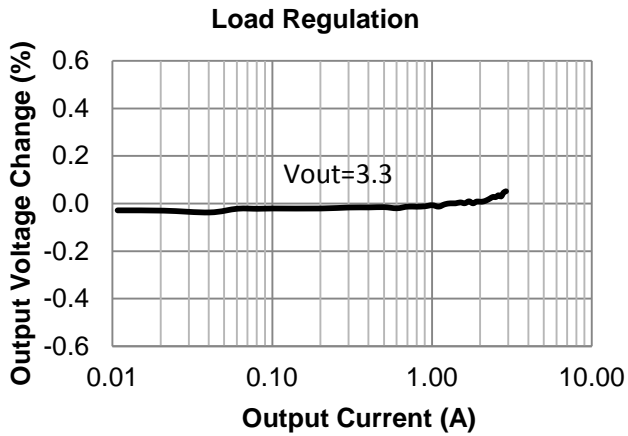

Typical Characteristics

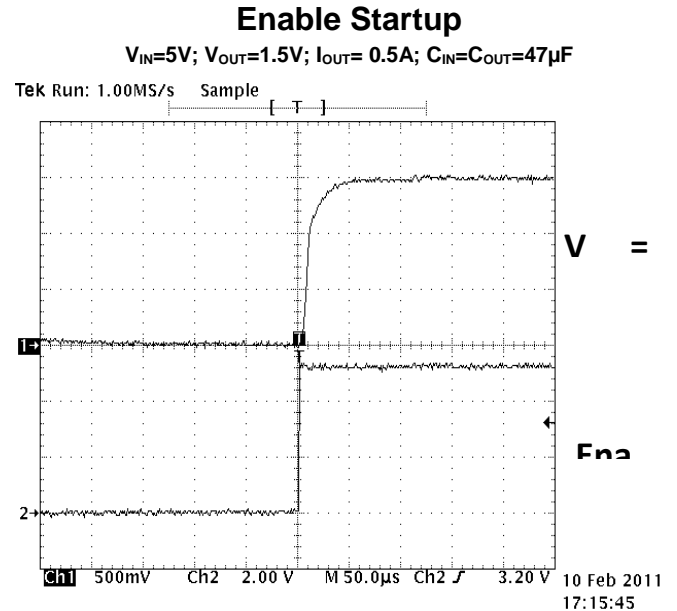
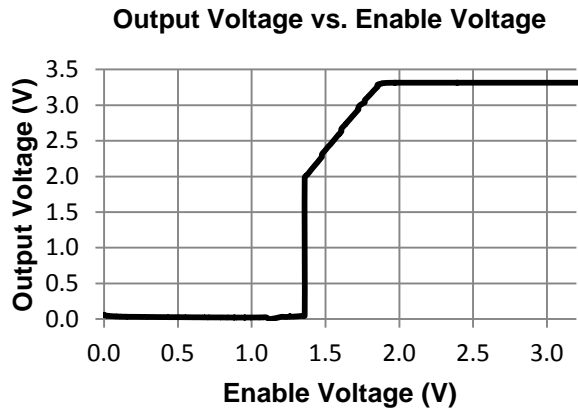

Application Hints

Input Capacitor (C_{IN})

An Input capacitor may be required when the device is not near the source power supply or when supplied by a battery. This capacitor will reduce the circuit's sensitivity when powered from complex source impedance and significantly enhance the output transient response. The input bypass should be mounted with the short possible track directly across the regulator's input and ground terminals. A $47\mu F$ ceramic or tantalum capacitor should be adequate for most applications.

Output Capacitor (C_{OUT})

The output capacitor provides not only stability to the regulator, but also, enhances the load transient response. Proper capacitor selection is important to ensure proper operation. A minimum capacitance of $47\mu F$ is required.

The output capacitor should have less than 1Ω of ESR. Ultralow ESR capacitors such as ceramic chip capacitors may promote instability. These very low ESR

levels may cause an oscillation. A low ESR solid tantalum capacitor works extremely well and provides good transient response and stability over temperature. Aluminum electrolytic can also be used as long as the ESR of the capacitor is $<1\Omega$.

Always consult capacitor manufacturer's data curves before selecting a capacitor. High-quality ceramic capacitors can be obtained from Taiyo-Yuden, AVX, and Murata. Higher values of the output capacitance can be used to enhance loop stability and transient response.

The value of the output capacitor can be increased without limit. Higher capacitance values help to improve transient response and ripple rejection and reduce output noise.

Enable

The enable (EN) pin is active high and is compatible with standard digital signaling levels. When V_{EN} is below $0.8V$, it turns the regulator off while V_{EN} above $2.4V$ turns the regulator on. If not used, EN can be connected to the input Voltage. If EN is connected to V_{IN} , it should be connected as close as possible to the largest capacitance on the input to prevent voltage droops on that line from triggering the enable circuit.

Power Good

The power good comparator has an open drain output stage. Hence, the power good pin requires an external pull-up resistor. The pull-up resistor should be about 100kΩ, and it should be connected to either the input voltage or the output voltage pin. For low current consumption, it is recommended to connect the pull-up resistor to V_{OUT}.

With the device being enabled, the power good pin will produce a logic low signal when the output voltage drops by more than 15% from the nominal output voltage. The drop in the power good voltage may be due to the low input voltage, current limiting, thermal limiting or when the device is disabled.

Output Voltage

The adjustable output voltage option allows the user to select an output voltage by using an external resistor divider. ASD3930X uses a 1.24V reference voltage at the positive terminal of the error amplifier. To set the output voltage, a programming resistor from the adjust pin (ADJ) to ground must be selected. A 10kΩ resistor is a good selection for a programming resistor R2. A higher value may result in an excessively sensitive feedback node while a lower value will draw more current and degrade the light load efficiency. The equation for selecting the voltage specific resistor is:

$$V_O = \left(1 + \frac{R1}{R2}\right) * V_{FB}$$

For the fixed output devices, R1 and R2 are included within the device.

Thermal Consideration

The ASD3930X is designed to provide 3A of continuous current. Maximum power dissipation can be calculated based on the output current and the voltage drop across the part. To determine the maximum power dissipation of the package, use the junction-to-ambient thermal resistance of the device and the following basic equation:

$$P_{D(max)} = \left(\frac{T_{J(max)} - T_A}{\theta_{JA}} \right)$$

Where T_{J(max)} is the maximum junction temperature of the die, T_A is the ambient operating temperature, and θ_{JA} is layout dependent. The actual power dissipation of the regulator circuit can be determined using the equation:

$$P_D = (V_{IN} - V_{OUT}) * I_{OUT} + V_{IN} * I_{SUP}$$

Substituting P_{D(max)} for P_D and solving for the operating conditions that are critical to the application will give the maximum operating conditions for the regulator circuit.

Ordering Information

Device	Package	Output Voltage	Packing Method & Quantity
ASD39300U-1.8	TO263-3L	1.8V	800 Tape & Reel
ASD39300U5-1.8	TO263-5L	1.8V	800 Tape & Reel
ASD39300U-2.5	TO263-3L	2.5V	800 Tape & Reel
ASD39300U5-2.5	TO263-5L	2.5V	800 Tape & Reel
ASD39300U-3.3	TO263-3L	3.3V	800 Tape & Reel
ASD39300U5-3.3	TO263-5L	3.3V	800 Tape & Reel
ASD39300U-5.0	TO263-3L	5.0V	800 Tape & Reel
ASD39300U5-5.0	TO263-5L	5.0V	800 Tape & Reel
ASD39301U-1.8	TO263-3L	1.8V	800 Tape & Reel
ASD39301U5-1.8	TO263-5L	1.8V	800 Tape & Reel
ASD39301U-2.5	TO263-3L	2.5V	800 Tape & Reel
ASD39301U5-2.5	TO263-5L	2.5V	800 Tape & Reel
ASD39301U-3.3	TO263-3L	3.3V	800 Tape & Reel
ASD39301U5-3.3	TO263-5L	3.3V	800 Tape & Reel
ASD39301U-5.0	TO263-3L	5.0V	800 Tape & Reel
ASD39301U5-5.0	TO263-5L	5.0V	800 Tape & Reel
ASD39302U	TO263-3L	Adjustable	800 Tape & Reel
ASD39302U5	TO263-5L	Adjustable	800 Tape & Reel

Outline Drawing and Landing Pattern – T0263-3L

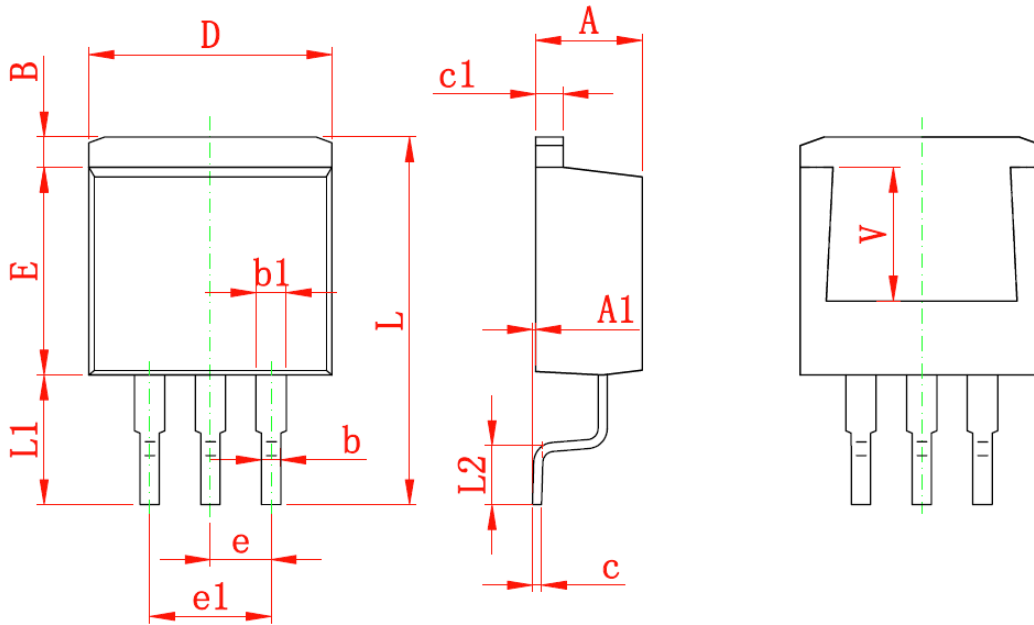

Symbol	Dimensions In Millimeters		Dimensions In Inches	
	Min	Max	Min	Max
A	4.470	4.670	0.176	0.184
A1	0.000	0.150	0.000	0.006
B	1.170	1.370	0.046	0.054
b	0.710	0.910	0.028	0.036
b1	1.170	1.370	0.046	0.054
c	0.310	0.530	0.012	0.021
c1	1.170	1.370	0.046	0.054
D	10.010	10.310	0.394	0.406
E	8.500	8.900	0.335	0.350
e	2.540 TYP		0.100 TYP	
e1	4.980	5.180	0.196	0.204
L	15.050	15.450	0.593	0.608
L1	5.080	5.480	0.200	0.216
L2	2.340	2.740	0.092	0.108
V	5.600 REF		0.220 REF	

Outline Drawing and Landing Pattern – T0263-5L

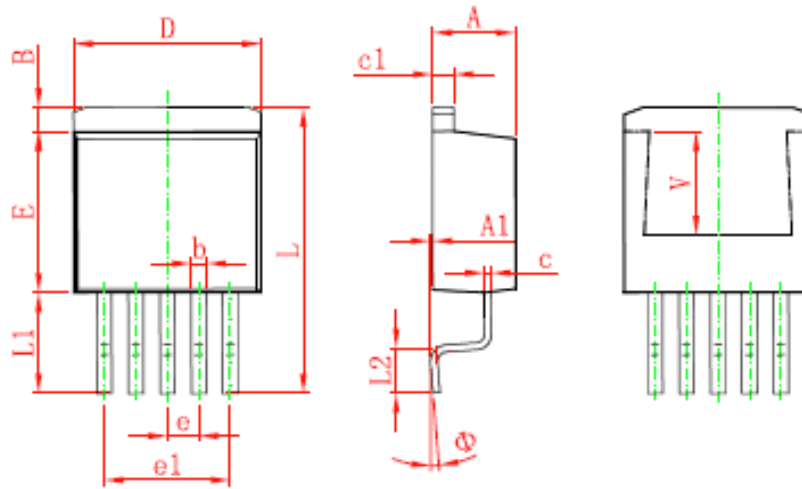

Symbol	Dimensions In Millimeters		Dimensions In Inches	
	Min.	Max.	Min.	Max.
A	4.470	4.670	0.176	0.184
A1	0.000	0.150	0.000	0.006
B	1.560	1.760	0.061	0.069
b	0.710	0.910	0.028	0.036
c	0.310	0.530	0.012	0.021
c1	1.170	1.370	0.046	0.054
D	9.880	10.180	0.389	0.401
E	8.200	8.600	0.323	0.339
e	1.700 TYP.		0.067 TYP.	
e1	6.700	6.900	0.264	0.272
L	15.140	15.540	0.596	0.612
L1	5.080	5.480	0.200	0.216
L2	2.340	2.740	0.092	0.108
Φ	0°	8°	0°	8°
V	5.600 REF.		0.220 REF.	

Disclaimer:

The information furnished in this data sheet is believed to be accurate and reliable. However, no responsibility is assumed by Golden Gate Integrated Circuits (GGIC) for its use. GGIC reserves the right to change circuitry and specifications at any time without notification to the customer.

- Golden Gate Integrated Circuits reserves the right to make changes to the information herein for the improvement of the design and performance without further notice! Customers should obtain the latest relevant information before placing orders and should verify that such information is complete and current.
- All semiconductor products malfunction or fail with some probability under special conditions. When using Golden Gate Integrated Circuits products in system design or complete machine manufacturing, it is the responsibility of the buyer to comply with the safety standards strictly and take essential measures to avoid situations in which a malfunction or failure of such Golden Gate Integrated Circuits products could cause loss of body injury or damage to property.
- Golden Gate Integrated Circuits (GGIC) Products are not designed or authorized for use as components in life support appliances, devices or systems where malfunction of a product can reasonably be expected to result in personal injury. Life support devices or systems are devices or systems that (a) are intended for surgical implant into the body or (b) support or sustain life, and whose failure to perform can be reasonably expected to result in a significant injury to the user. A Purchaser's use or sale of GGIC Products for use in life support appliances, devices or systems is a Purchaser's own risk and Purchaser agrees to fully indemnify GGIC for any damages resulting from such use or sale.