

Buck/Boost/Buck-Boost LED Driver

General Description

The GGD42560 is PWM control LED driver with Buck/Boost/Buck-Boost modes, thermal shutdown circuit, current limit circuit, and PWM dimming circuit. Good line regulation and load regulation are available over a wide range of input voltage.

The GGD42560 adopts current mode control which provides fast transient response, excellent constant current characteristics, and simple loop stabilization design. It has high efficiency: 96% for buck mode, 83% for buck-boost mode and 95% for boost mode,

Features

- 5~36V input voltage range
- Maximum 1A output current (Buck mode)
- 0.3Ω built-in power MOSFET
- PWM dimming function
- 280kHz fixed frequency
- Excellent constant current accuracy ±3%
- High efficiency up to 96%.
- Thermal shutdown
- Cycle-by-cycle over current protection
- Over voltage protection (boost/buck-boost mode)

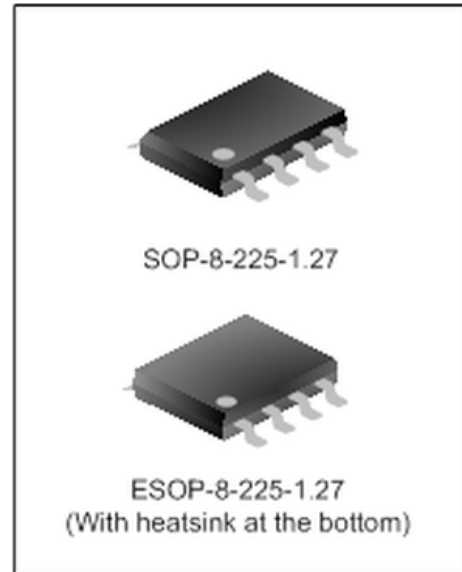

Applications

- MR16 LED spotlight
- LED illuminance
- LCD backlight illumination
- Automotive interior lighting
- Portable Multi Media Player
- Portable GPS device

Ordering Information

Part No.	Package	Marking	Material	Packing
GGD42560	SOP-8-225-1.27	GGD42560	Pb free	Tube
GGD42560TR	SOP-8-225-1.27	GGD42560	Pb free	Tape & Reel
GGD42560E	ESOP-8-225-1.27	GGD42560E	Pb free	Tube
GGD42560ETR	ESOP-8-225-1.27	GGD42560E	Pb free	Tape & Reel

Block Diagram

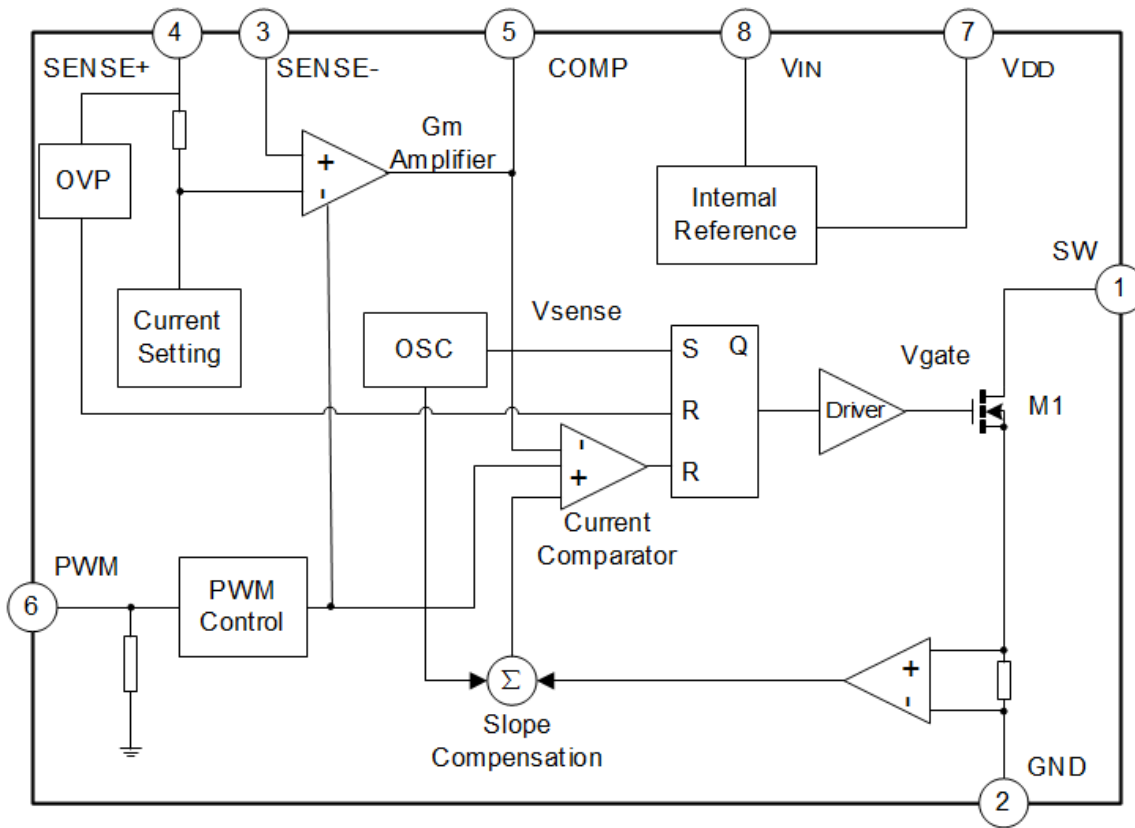

Absolute Maximum Ratings (Operating Temperature Range Applies Unless Otherwise Specified)

Characteristics	Symbol	Ratings	Unit
Supply Voltage	V_{IN}	40	V
Switch Voltage	V_{SW}	$-1 \sim V_{IN} + 1$	V
PWM Voltage	V_{PWM}	$-0.3 \sim 6$	V
Comp Voltage	V_{COMP}	$-0.3 \sim 6$	V
SENSE- Voltage	V_{SENSE-}	$-0.3 \sim V_{IN}$	V
SENSE+ Voltage	V_{SENSE+}	$-0.3 \sim V_{IN}$	V
Junction Temperature	T_j	150	°C
Lead Temperature	T_L	260	°C
Input Voltage Range	V_{IN}	5~36	V
Operating Temperature Range	T_{OPR}	-40~125	°C
Storage Temperature Range	T_{STG}	-65~150	°C

Electrical Characteristics (Unless otherwise specified, $V_{IN}=12V$, $I_{OUT}=700mA$, $T_{amb}=25^{\circ}C$)

Characteristics	Symbol	Test Condition	Min.	Typ.	Max.	Unit
Supply Voltage	V_{IN}		5		36	V
Operating Current	I_{IN}	$V_{CC}=5/36V, V_{PWM}=5V$		1.5	2.0	mA
Transistor Leakage Current	I_L	$V_{SW}=36V$		0	5	μA
Switch Transistor on Resistance	R_{ON}	1LED, $I_{OUT}=0.5A$		0.3	0.5	Ω
Current Limit	I_{LIM}	SENSE+ is connected to SENSE-	1.7	2.0	2.3	A
Maximum Duty Cycle	Dmax	3LED, $V_{IN}=9V$	--	93	95	%
Oscillator Frequency	f_{osc}		250	280	320	kHz
PWM Dimming On Voltage	V_{PWMON}	V_{PWM} is from 0V to 5V, On voltage	2.2	2.4	2.6	V
PWM Dimming Off Voltage	V_{PWMOFF}	V_{PWM} is from 5V to 0V, Off voltage	1.9	2.0	2.1	V
PWM Pull-Down Current	I_{PWM1}	$V_{PWM}=5V$	14	15	18	μA
PWM dimming frequency	F_{PWM}		100		2000	HZ
Comp Clamp Voltage	V_{COMP}	Open without load	1.6	1.9	2.2	V
Output over voltage protection	OVP	BOOST, without load	38	40	42	V
VDD Voltage	V_{DD}	No load	5.0	5.2	5.4	V
Sampling Voltage Threshold	$V_{IN}-V_{SENSE}$	Drop voltage between V_{IN} and SENSE	--	100	--	mV
Thermal Shutdown Threshold	TSD			160		$^{\circ}C$

Note: Considering the efficiency and other factors, the input voltage recommended to be less than 25V in BUCK-BOOST mode.

Pin Configuration

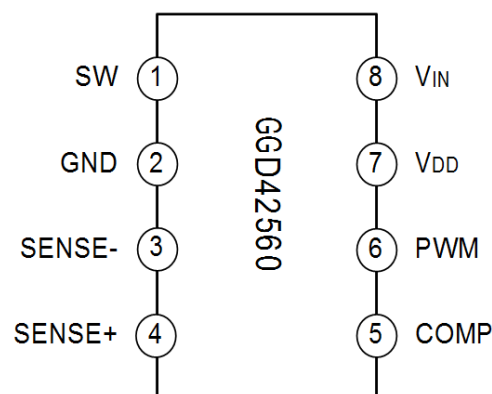

Pin Description

Pin No.	Pin Name	I/O	Description
1	SW	I	Power output
2	GND	O	Ground.
3	SENSE-	I	Current sense- pin.
4	SENSE+	O	Current sense+ pin.
5	COMP	I/O	Compensation pin, connects to external complement
6	PWM	I	PWM dimming pin, connects PWM signal to change the output current.
7	V _{DD}	I	5V reference output
8	V _{IN}	I	Input voltage

Function Description

The GGD42560 is the current mode LED driver used in three modes for different applications: Buck, Boost and Buck—Boost for different LEDs.

Buck mode principle: at the beginning of a cycle, internal transistor is triggered on by the signal output from OSC. SW outputs low, and the circuit loop is composed of V_{IN}, R_S, LED, inductor, internal transistor and GND. Current flowing through the inductor increases and is sensed by SENSE- and SENSE+, the error amplifier signal between the sensed value and the threshold value is compared with transistor peak current. Transistor is off when its peak current is up to the error amplifier signal. And energy of inductor is released through the circuit loop comprised by R_S, LED, inductor, Schottky diode, with current decreases. When the next clock pulse comes, transistor is on for the next period.

Boost mode principle: at the beginning of a cycle, internal transistor is triggered on by the signal output from OSC. SW outputs low and the circuit loop is composed of V_{IN}, inductor, internal transistor and GND, and current flowing through the inductor increases. Current in LED is sensed by SENSE- and SENSE+, the error amplifier signal between the sensed value and the threshold value is compared with transistor peak current. Transistor is off when its peak current is up to the error amplifier signal. And LED is powered by the circuit comprised by V_{IN}, inductor, Schottky diode, R_S, LED and GND with power supply of power drop on V_{IN+} inductor. When the next clock pulse comes, transistor is on for the next period.

Buck—Boost mode principle: at the beginning of a cycle, internal transistor is triggered on by the signal output from OSC. SW outputs low and the circuit loop is composed of V_{IN}, inductor, internal transistor and GND, and current flowing through the inductor increases. Current in LED is sensed by SENSE- and SENSE+, the error amplifier signal between the sensed value and the threshold value is compared with transistor peak current. Transistor is off when its peak current is up to the error amplifier signal. And LED is powered by the circuit comprised by inductor, Schottky diode, R_S, and LED, current through inductor decreases. When the next clock pulse comes, transistor is on for the next period.

1. PWM dimming function

GGD42560 has internal PWM dimming function. When PWM pin connects to high level, the chip is working normally; when PWM pin is open or connects to low level, COMP pin disconnects with the chip, the charge of the capacitor is in hold state, voltage level holds, and the output of current comparator is high, transistor is off without output current. When PWM signal is high, COMP pin is connected with the chip to improve the startup speed of the chip. Adjust the output current by control the duty of external PWM signal.

The minimum setup time of GGD42560 PWM dimming is less than 20 μ S, and the maximum PWM dimming ratio is up to 500:1. When high dimming ratio is needed, the dimming frequency is recommended 500Hz below; or else the dimming frequency can be up to 2 KHz.

2. Output current setting

The output current is determined by the sense resistor and setting voltage. The sense voltage of difference of V_{SENSE+} and V_{SENSE-} (Drop voltage on R_S) is 100mV, and adjust the output current by adjusting the sense resistor R_S (refer to Typical Application Circuit).

$$I_{OUT} = \frac{V_{SENSE+} - V_{SENSE-}}{R_S}$$

3. Current limiting

GGD42560 has internal current limiting function, and the voltage on COMP is clamped at about 1.9V, the output current of the power MOSFET is limited at about 2.5A by current comparator.

4. Frequency jitter

GGD42560 has internal frequency jitter function to improve the EMI performance of the system. The internal frequency is hopping in a very small range to reduce the single frequency radiation which simplifies the EMI design.

5. Output over voltage protection

With boost/buck-boost mode, the IC will still work if voltage on sense resistor R_S is 0 when LED is open, and the peak current will be increased to the limit. Voltage at SENSE+ will be continuously increased if there is no protection and components will be damaged. With the over voltage protection, voltage at SENSE+ is monitored by internal OVP module, and power MOSFET is off if it is higher than 40V to guarantee the safety.

Components Selection

1. Input Capacitor Selection

The input capacitor provides the pulse current when the power MOSFET is on, and capacitor is charged when the power MOSFET is off, so input voltage is kept. At the switch frequency, impedance of input capacitor should be less than that of input source to avoid high-frequency switch current from input source. The input capacitor is recommended to be larger than 10 μ F, which can reduce the peak current drawn from input source and the switch noise. The input capacitor should be near to the input pin in real routing.

2. Output Capacitor Selection

Ripple current of LED can be reduced through decreasing the output voltage ripple by connected a capacitor to LED in parallel, and the circuit becomes more stable, while this capacitor will not effect the operating frequency and efficiency, but the start time will be longer by reducing the rising speed of the voltage on LED. The larger the output capacitor is, the smaller the current ripple on LED is. It is recommend to adopt the capacitor of 2.2 μ F or larger.

3. Inductor Selection

The inductor is used to keep the output current constant, the bigger the inductance is, the smaller the output current ripple is, but the larger size will bring the larger serial resistance.

Inductor selection for buck mode:

The effective current (RMS current rating) of inductor should be higher than the maximum output current, and the saturation current should be higher than maximum output current by 30%. The series resistance (DCR) of inductor should be lower than 0.2Ω for improving the efficiency.

The inductance is expressed as:

$$L = V_{OUT} * \frac{V_{IN} - V_{OUT}}{V_{IN} * f * \Delta I}$$

Where, L: inductance

f: oscillation frequency

ΔI: ripple current

V_{IN}: input voltage,

V_{OUT}: output voltage

The ripple current ΔI is 30% of maximum load current and the minimum inductance can be calculated according to the equation above. The recommended inductance value is: 22μH~47μH.

Inductor selection for boost-buck mode:

The inductance is expressed as:

$$L = V_{OUT} * \frac{V_{IN}}{(V_{IN} + V_{OUT}) * f * \Delta I}$$

Recommended inductance value range: 22μH~47μH.

4. Diode Selection

The forward voltage drop of Schottky diode is very low and the reverse freewheeling current time is short, so it is usually used for freewheeling current. The voltage on diode is very high when power MOSFET is on, and the reverse voltage of diode should be higher than the input or output voltage. Rated current of freewheeling diode should be higher than the peak current of inductor, select the freewheeling diode according to practical application.

5. Notes for PCB routing

Proper PCB routing is important for system reliability and reducing noise. Multi-layer PCB can be adopted for reducing noise interference. PCB line connecting SW should be short and GND should be well grounded.

The inductor should be connected to EW as close as possible and lines connecting two ends of R_S should be short to reduce parasitic resistance and to guarantee the accuracy of sense current.

Typical Application Circuits

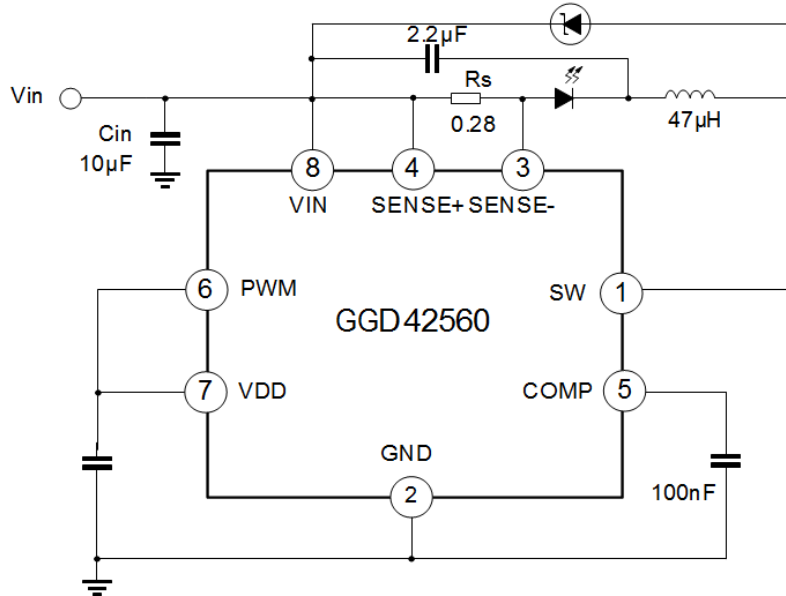

5~36V input voltage, 350mA output buck LED driver ($V_{IN} > V_{OUT}$)

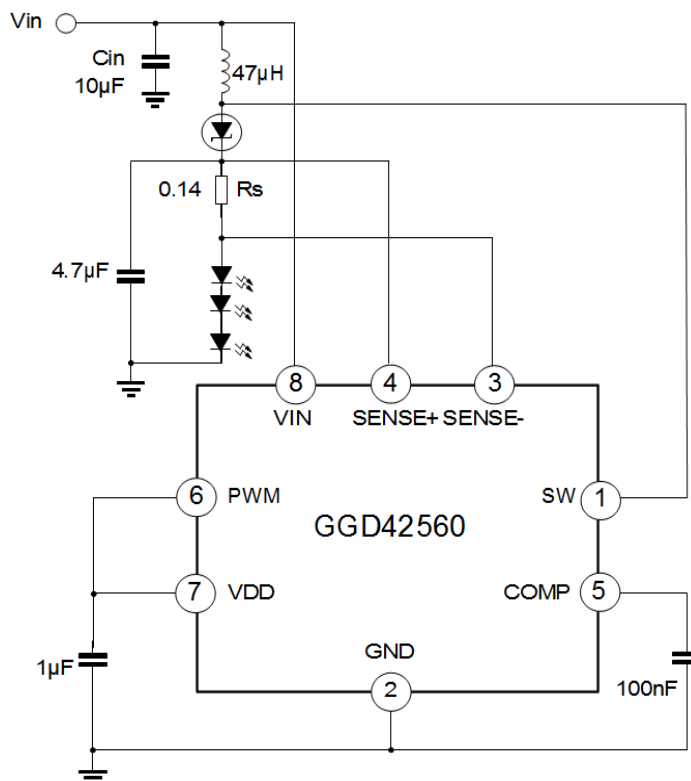

6~12V input voltage, 700mA output boost LED driver ($V_{IN} < V_{OUT}$)

Typical Application Circuits (Continued)

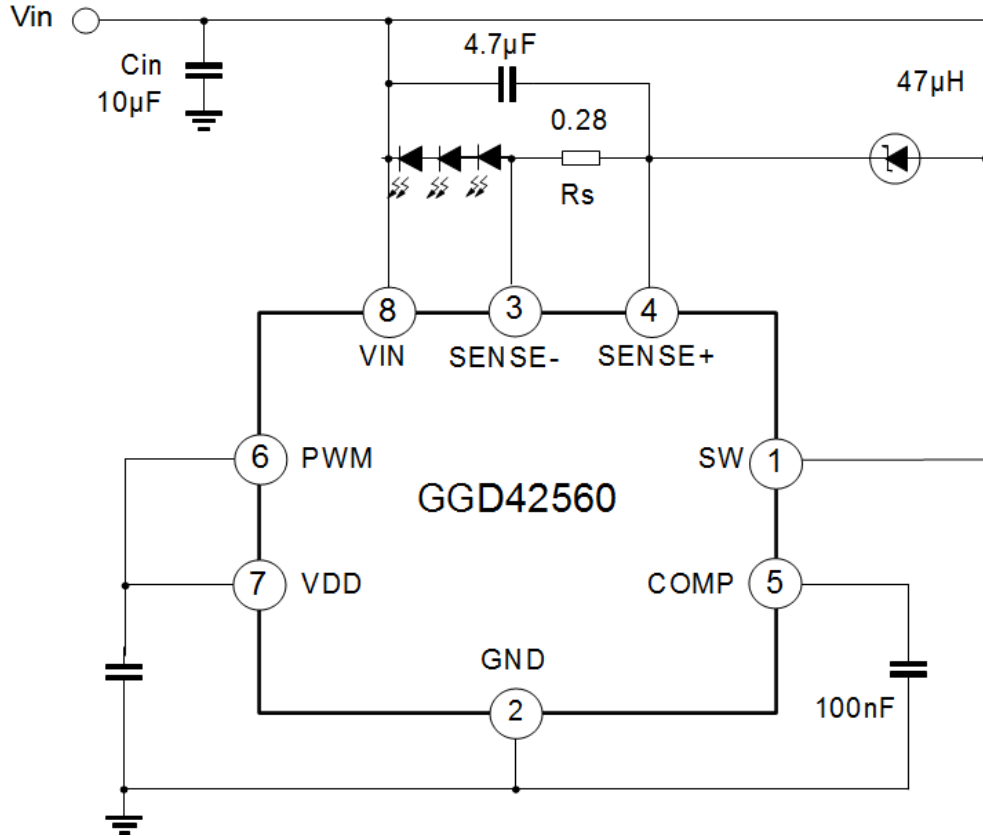

6~18V input voltage, 350mA output buck-boost LED driver

Typical Characteristics (curves are for BUCK mode, unless otherwise noted)

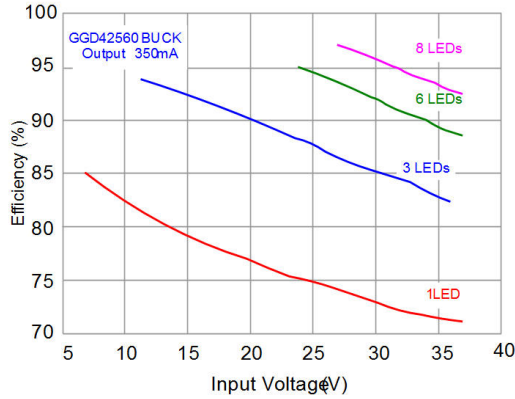

BUCK Output 350mA efficiency changed following the input voltage

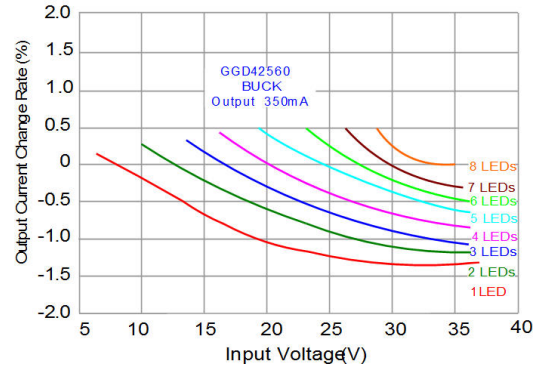

BUCK Output 350mA current change rate following the input voltage change

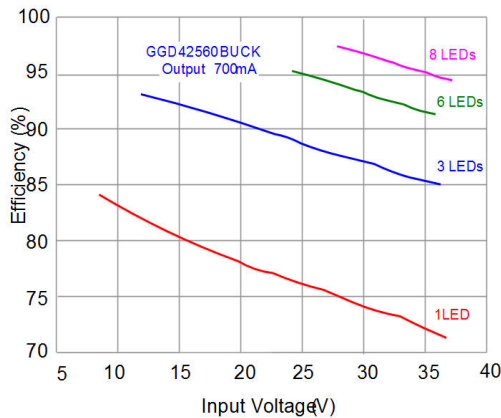

BUCK Output 700mA efficiency changed following the input voltage

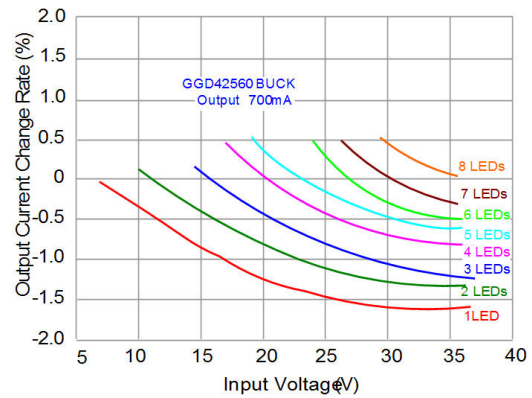

BUCK Output 700mA current change rate following the input voltage

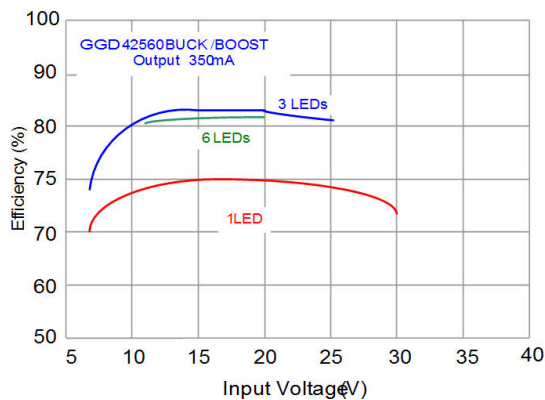

BUCK/BOOST Output 350mA efficiency changed following the input voltage

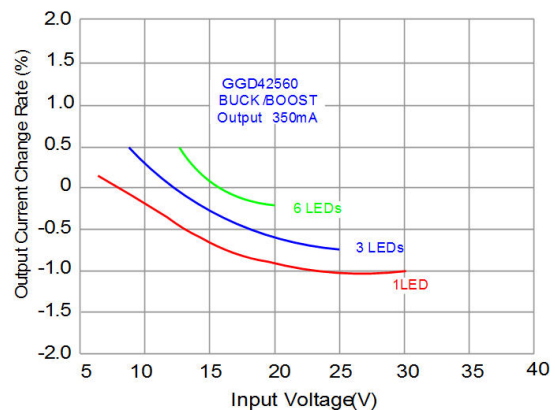

BUCK/BOOST Output 350mA current change rate following the input voltage change

Typical Characteristics (continued)

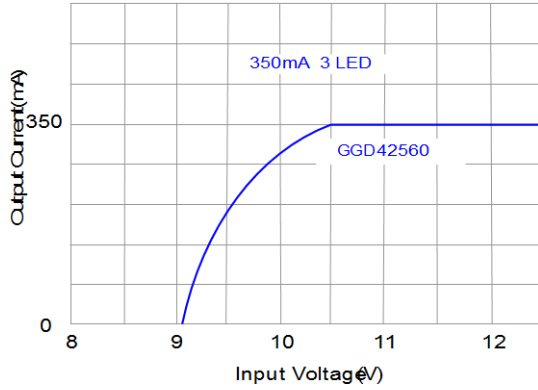

BUCK Output current change curve when input voltage is close to output voltage(350mA)

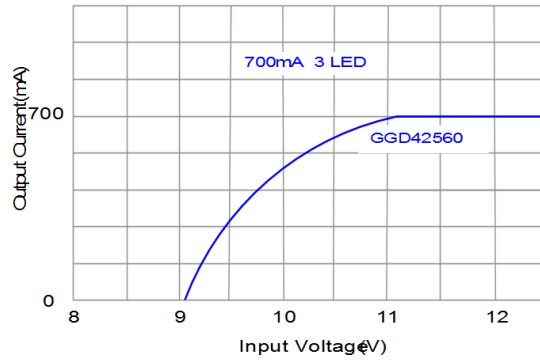

BUCK Output current change curve when input voltage is close to output voltage(700mA)

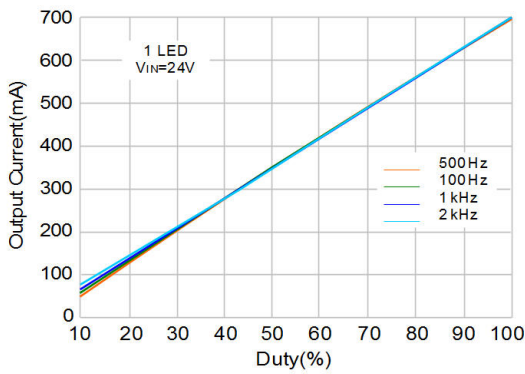

BUCK PWM dimming behavior of 1 LED(700mA)

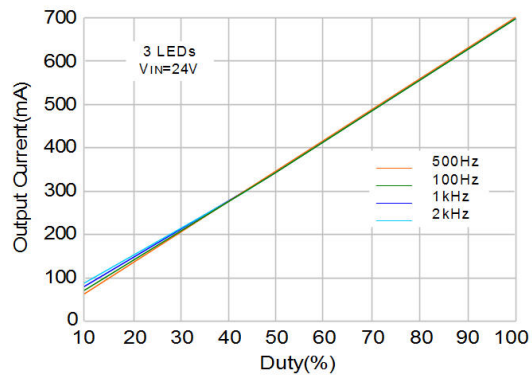

BUCK PWM dimming behavior of 3 LEDs(700mA)

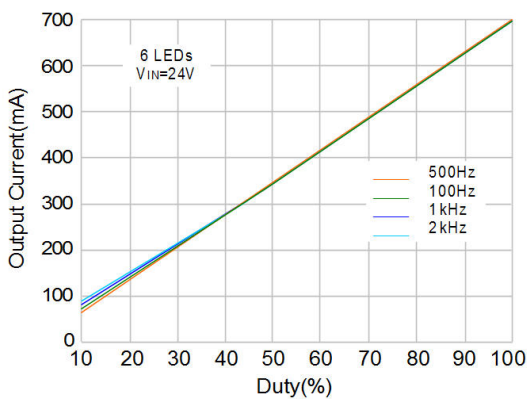

BUCK PWM dimming behavior of 6 LEDs(700mA)

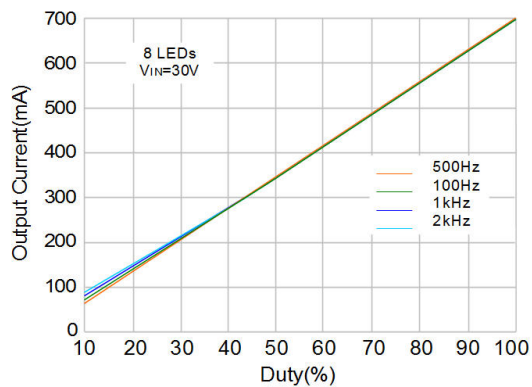

BUCK PWM dimming behavior of 8 LEDs(700mA)

Package Outline

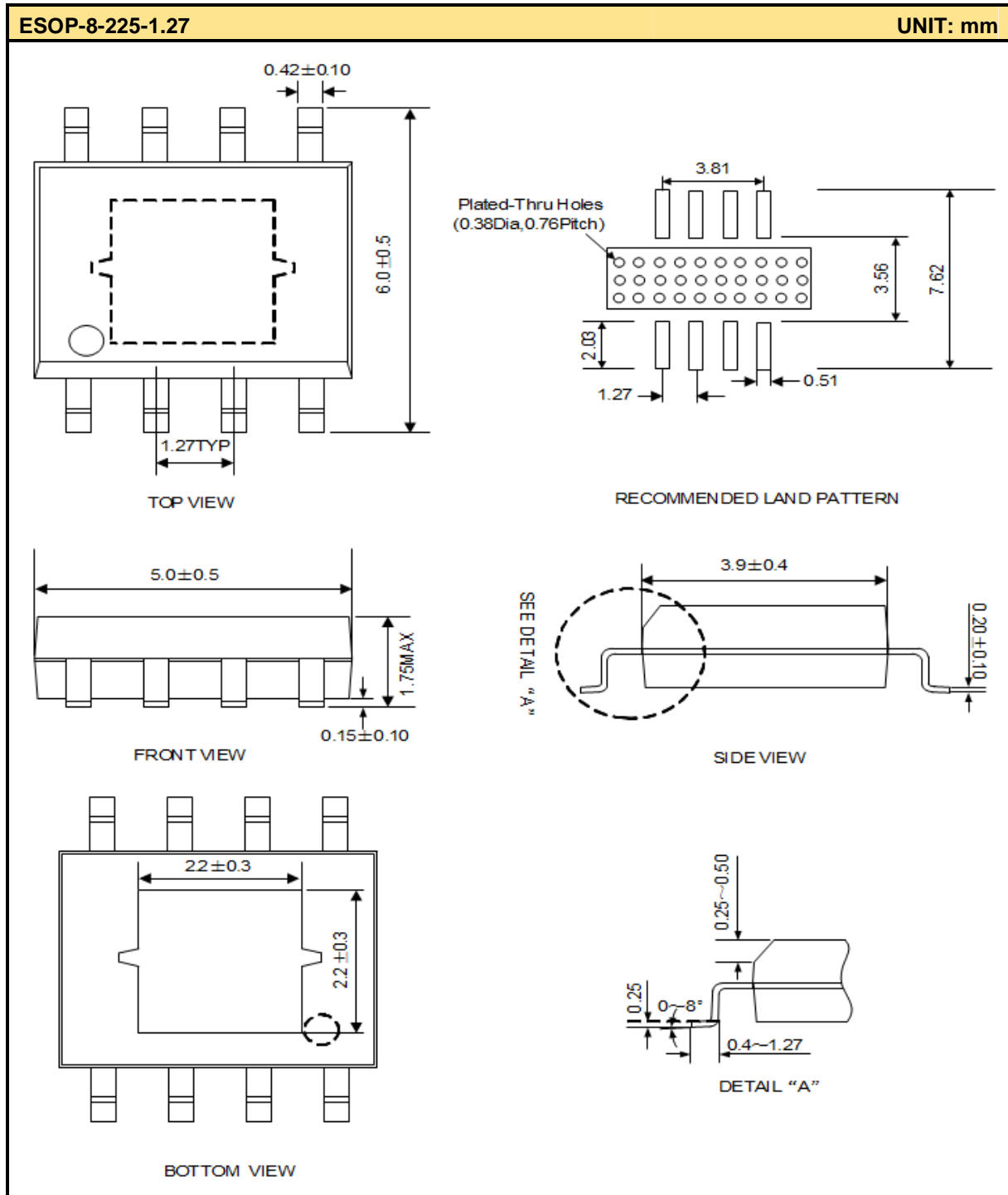

Note:

Please solder together the PCB copper foil and pad which is at the bottom of ESOP package, and enlarge the copper foil on PCB for heat dissipation. Use extra plated-thru holes on PCB attached to PAD.

Package Outline (continued)

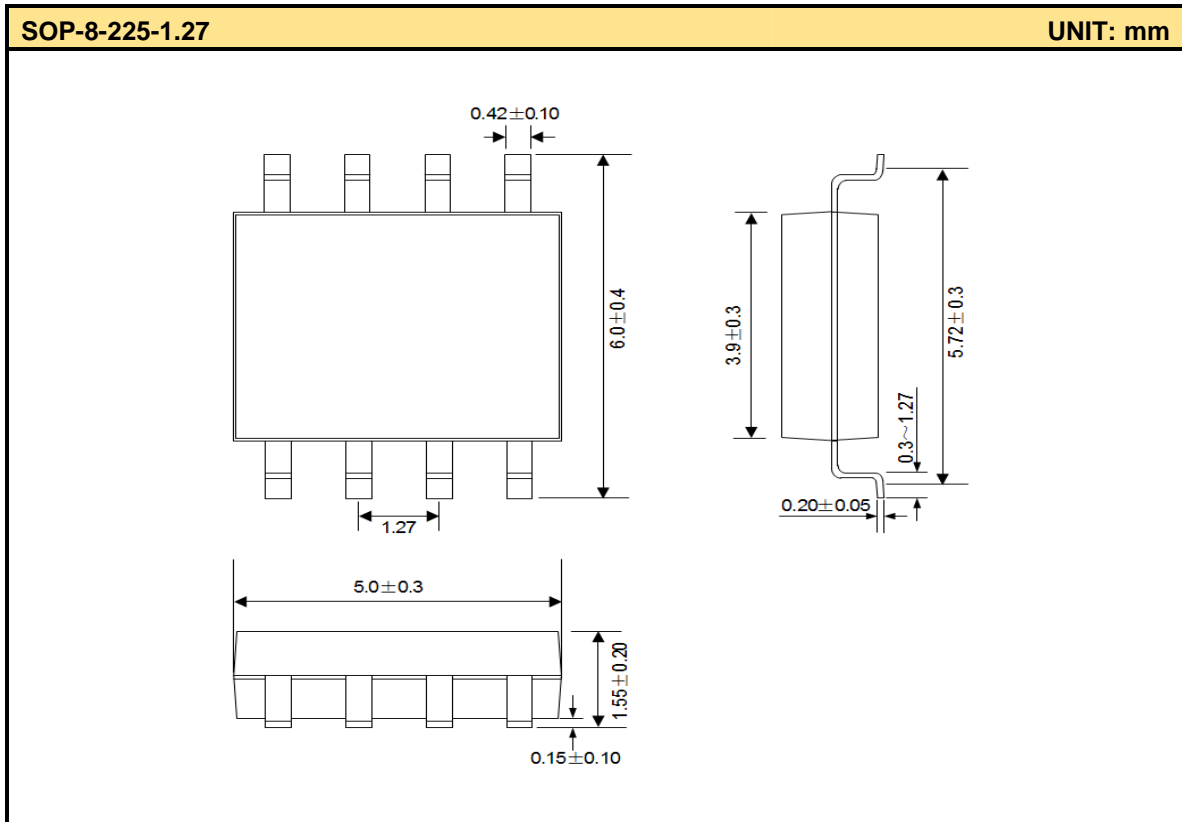

MOS DEVICES OPERATE NOTES:

Electrostatic charges may exist in many things. Please take following preventive measures to prevent effectively the MOS electric circuit as a result of the damage which is caused by discharge:

- The operator must put on wrist strap which should be earthed to against electrostatic.
- Equipment cases should be earthed. •
- All tools used during assembly, including soldering tools and solder baths, must be earthed.
- MOS devices should be packed in antistatic/conductive containers for transportation.

Disclaimer:

The information furnished in this data sheet is believed to be accurate and reliable. However, no responsibility is assumed by Golden Gate Integrated Circuits (GGIC) for its use. GGIC reserves the right to change circuitry and specifications at any time without notification to the customer.

- Golden Gate Integrated Circuits reserves the right to make changes to the information herein for the improvement of the design and performance without further notice! Customers should obtain the latest relevant information before placing orders and should verify that such information is complete and current.
- All semiconductor products malfunction or fail with some probability under special conditions. When using Golden Gate Integrated Circuits products in system design or complete machine manufacturing, it is the responsibility of the buyer to comply with the safety standards strictly and take essential measures to avoid situations in which a malfunction or failure of such Golden Gate Integrated Circuits products could cause loss of body injury or damage to property.
- Golden Gate Integrated Circuits (GGIC) Products are not designed or authorized for use as components in life support appliances, devices or systems where malfunction of a product can reasonably be expected to result in personal injury. Life support devices or systems are devices or systems that (a) are intended for surgical implant into the body or (b) support or sustain life, and whose failure to perform can be reasonably expected to result in a significant injury to the user. A Purchaser's use or sale of GGIC Products for use in life support appliances, devices, or systems is a Purchaser's own risk and Purchaser agrees to fully indemnify GGIC for any damages resulting from such use or sale.
-